

Method for improving EMC of Small Scale Resistance Spot Welding Equipment

Denys Spitsyn

Industrial Electronics Department,
National Technical University of Ukraine
"Igor Sikorsky Kyiv Polytechnic Institute"
Kyiv, Ukraine
spitsyndenys@gmail.com

Oleksandr Bondarenko

Industrial Electronics Department,
National Technical University of Ukraine
"Igor Sikorsky Kyiv Polytechnic Institute"
Kyiv, Ukraine
bondarenkoaf@gmail.com

Abstract—The features of micro resistance welding are described. The issue of designing the power supplies for resistance welding equipment with high electromagnetic compatibility with the network is considered. The topologies of the input circuit of the power supply based on common types of converters, such as buck, boost, buck-boost, SEPIC and Cuk, are analyzed. The input converter topology based on SEPIC is determined as the most efficient. The efficiency of the suggested solutions is verified in MATLAB Simulink.

Keywords—*electromagnetic compatibility; total harmonic distortion; micro resistance welding; multicell-type power supply; SEPIC; IEC standards*

I. INTRODUCTION

In order to get highly reliable permanent joints in heavy engineering industry as well as in manufacturing the miniature electronic components, resistance welding is widely used now due to its low cost and simplicity. A type of resistance welding for joining small-scale parts is called micro resistance spot welding.

The technological feature of implementing the resistance spot welding is pulsed energy consumption from the network that causes non-sinusoidal input current and worsens the electromagnetic compatibility (EMC) of welding equipment.

There are a number of methods to improve electromagnetic compatibility of power supplies for resistance welding with the network. Among them, the following methods:

- using the intermediate energy storage,
- using the power factor corrector (PFC),
- applying the multiphase topology of input circuit,
- applying the special control algorithms.

As for the way of energy consumption from the network, the power supplies for resistance welding may be divided into two groups: with direct power consumption from the network – Direct Energy Type and with intermediate energy storage – Energy Storage Type [1-3]. The first one highly influences the network and has low energy efficiency. That is why the second one becomes more widely used recently [3-7]. The power supplies based on the Energy Storage topology usually have more complicated structure and require using the multicell-type storage with low internal resistance and high energy capacity, such as supercapacitors.

Applying the PFC, especially the ones of multiphase interleaved type, makes it possible to improve EMC of welding power supplies, as well as to reduce weight and size of the equipment.

The aim of this work is to choose the most efficient topology for constructing the input circuit of power supply for micro resistance welding, which provides improvement of electromagnetic compatibility of welding equipment with the network.

II. THE FEATURES OF MICRO RESISTANCE WELDING

The basis of resistance welding is a physical phenomenon of resistive heating with subsequent melting the welded parts in the place of their contact while the electric current flows through them. One of the main parameters of welding contact is its dynamic resistance. It is composed of contact and bulk resistances. The contact resistance is determined by contaminants and roughness of welded surfaces. The bulk resistance depends on temperature. The changes of these parameters over the welding time are illustrated in Fig.1 *a* [2].

The figure shows that the contact resistance quickly decreases during the welding process. This is due to purification from grease contaminants and surface oxides, and reducing the surface roughness of welded parts at high temperature.

The bulk resistance conversely increases over the temperature rise that is typical for metals overall. However, it weakly influences the final dynamic resistance of the welding contact. The change of the last one is shown in Fig. 1 *b* [2].

It demonstrates that for the first 2% of the time, the resistance 6 times decreases. This change is due to a sharp decline of a contact resistance. Further heating leads to an increase of a bulk resistance. However, the subsequent metal melting causes the reduction of a contact resistance and dynamic resistance as a whole [2].

To take into account the electrophysical processes in the welded contact described above and to provide the high quality joints without such common defects as splashes, burnouts or lacks of penetration, the welding current pulses should be formed according to special laws, which depend on specific welding conditions. Some typical forms of welding pulses are shown in Fig. 2 [8].

The work has been supported by the IEEE Standards Education Grant for Student Application Papers Implementing Industry Standards from the IEEE Standards Education Committee.

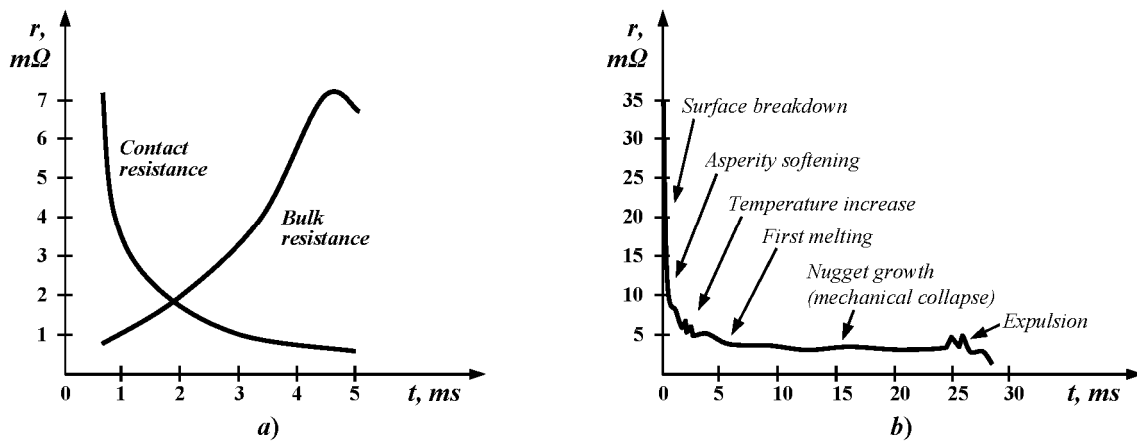

Fig. 1. The character of Contact and Bulk resistances' changes (a) and the character of Dynamic resistance change (b) [2].

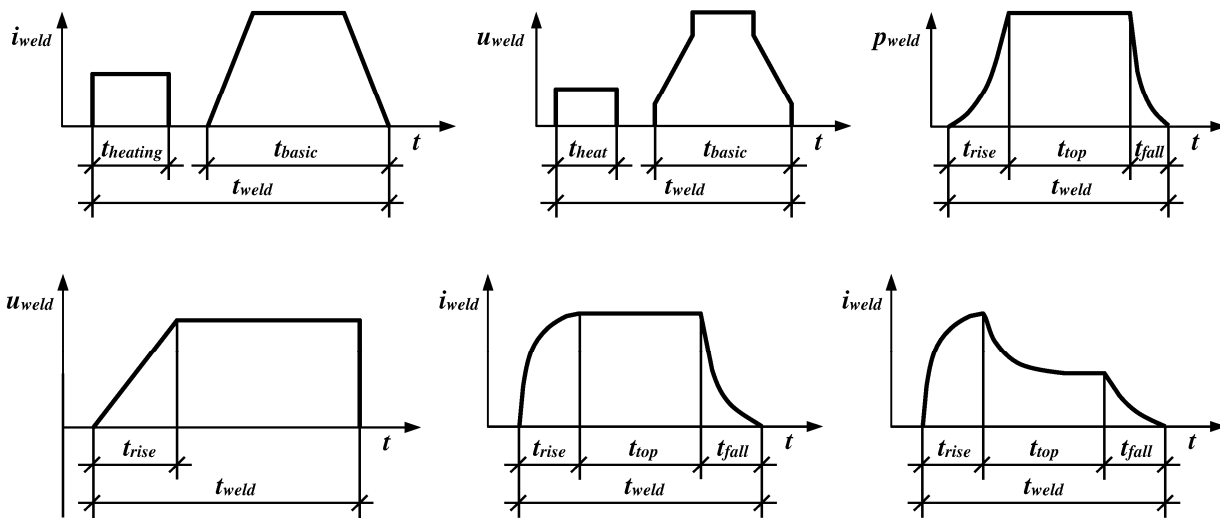

Fig. 2. The special laws of welding pulses [8].

Because of pulsed character of resistance welding process, the input current of power supply is sharply distorted and non-sinusoidal. This leads to a distortion of the network voltage and is able to cause a negative impact on apparatus that works simultaneously with the welding equipment. In addition, the welding devices running in parallel are exposed to a negative impact of each other.

Therefore, the issue of improving the electromagnetic compatibility with the network is one of the major matters of designing the resistance welding equipment.

III. THE DESIGN OF POWER SUPPLY FOR MICRO RESISTANCE WELDING

The generalized block diagram of the power supply for micro resistance welding is shown in Fig. 3.

The blocks of the power supply perform the following functions. The input converter provides necessary energy for welding. It is represented in Fig. 3 in two variants: charger + energy storage (Energy Storage Type) or matching transformer + rectifier (Direct Energy Type). For the considered power

supply, the first variant was chosen. The pulse generator provides the current pulses for the load, according to the required profile specified by the control system. The parameters of welding pulses are controlled during the welding process with feedback signals from the sensors in the load.

Below, the possible topologies of the input circuit of the power supply for resistance welding will be analyzed and the most effective one will be suggested.

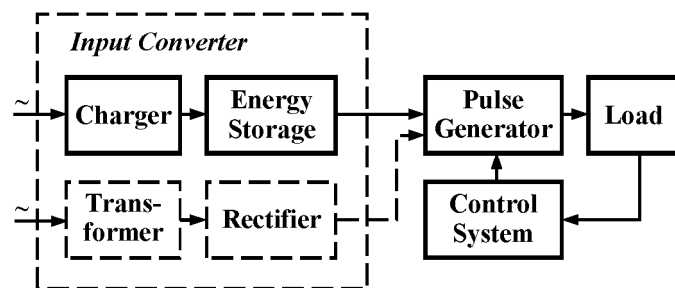

Fig. 3. Generalized block diagram of the power supply for micro resistance welding.

As an energy storage of the input circuit of the power supply it is expediently to choose a supercapacitor battery because of its low internal resistance, high energy capacity and small dimensions.

The charger for supercapacitor storage module should performs the following functions: to form the sinusoidal input current; to separate the network and the load galvanically; to charge the storage with direct or pulsating current.

To form the sinusoidal input current, the power factor corrector is required. The basic circuit of PFC [9] is quite simple but it does not provide the acceptable values of total harmonic distortion (*THD*) of the input current. To improve the values of *THD*, the multiphase topology of PFC is applied. The multiphase PFC may include an unlimited number of unified cells (phases) connected in parallel, which operate with some phase shift. The input current in this case is a sum of the currents of PFC cells and its ripples are smaller than in the basic single-phase topology.

Because of intention to use the supercapacitors (which have maximal voltage 2.7 V [10]) as the energy storages, the step-down transformer is required to decrease the input voltage and to isolate the network and the load galvanically.

To charge the supercapacitor storage with direct or pulsating current, it is necessary to use the converter, which should meet the following requirements:

1. The availability of the input inductor, which forms the continuous current, consumed from the network;
2. The possibility of soft start and soft regulation of the input current;
3. The possibility of the transformer integration into the structure of the converter.

At nowadays, several basic PFC converter topologies are known. The simplest are Boost and Buck [9]. The Buck-Boost topology combines the advantages of both. However, to get better values of *THD* and power factor (*PF*) the attention should be paid for SEPIC and Cuk topologies.

The Table I shows the compliance of the converters of different types to the above requirements. It may be concluded that the most appropriate converter types for the considered task are SEPIC and Cuk. The analysis of these types of converters [11] showed that the SEPIC has lower input current ripples and better controllability than Cuk. Therefore, SEPIC is preferable to choose as basic topology for designing the charger cell.

The main circuit of SEPIC is shown in Fig. 4. The circuit of the charger based on SEPIC cells is represented in Fig. 5.

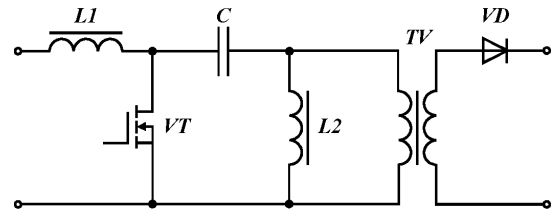

Fig. 4. The main circuit of the SEPIC converter.

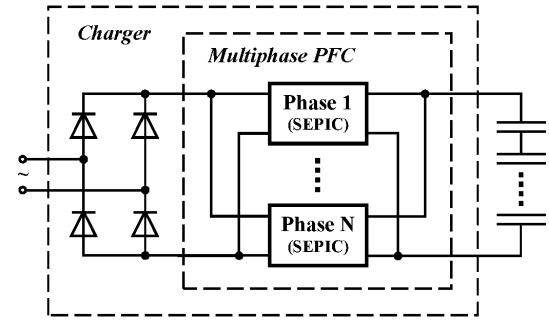

Fig. 5. The input circuit of the power supply.

To calculate the parameters of the input circuit of the designed power supply correctly, it is necessary to consider the current standards regulating the quality of energy consumed by welding equipment from the network.

Let's consider the standards in the next section.

IV. USING THE STANDARDS

For the stated aim, the following two International Electrotechnical Commission standards are chosen:

- IEC 61000-3-3, which regulates limitation norms of energy consumption for the devices, connected to low-voltage supply systems with rated current ≤ 16 A (per phase) [12],
- IEC 62135-2, which regulates standards of electromagnetic compatibility for electrical resistance welding equipment, connected to AC power supply with nominal voltage up to 1000 V [13].

From the standard IEC 61000-3-3 the following limits are taken:

- the maximum relative steady-state voltage change $d_c < 3.3\%$,
- the maximum relative voltage change for equipment, which is attended whilst in use or – switched on automatically, or is intended to be switched on manually, no more than twice per day, and also has either a delayed restart (the delay being not less than a few tens of seconds) or manual restart, after a power supply interruption $d_{max} < 7\%$.

A steady state condition exists when the half period r.m.s. voltage U_{hp} remains within the specified tolerance band of $\pm 0.2\%$ for a minimum of 100 half cycles of the fundamental frequency (50 Hz). The maximum relative steady-state voltage change is calculated according to the following equations:

$$d_c = \Delta U_{hp} / U_n \quad (1)$$

TABLE I. COMPLIANCE OF THE CONVERTERS TO THE SPECIFIED REQUIREMENTS

Converter Type	Requirements		
	1	2	3
Buck	-	+	+/-
Boost	+	-	-
Buck-boost	-	+	+
SEPIC	+	+	+
Cuk	+	+	+

$$\Delta U_{hp} = \Delta U_{hp1} - \Delta U_{hp2} \quad (2)$$

From the standard IEC 62135-2 the following limit was taken: maximum permissible harmonic current for equipment with input current $I_{lcc} \leq 16$ A (Table II).

TABLE II. HARMONIC CURRENT LIMITS

Harmonic order	Harmonic current
<i>Odd harmonics</i>	
3	3.45
5	1.71
7	1.16
9	0.6
11	0.5
13	0.32
$15 \leq n \leq 39$	$0.23 \times 15/n$
<i>Even harmonics</i>	
2	1.62
4	0.65
6	0.45
$8 \leq n \leq 40$	$0.35 \times 8/n$

The limit values above will be taken into account in calculations and simulations of the next section.

V. THE SIMULATION OF SEPIC CHARGER

The dimensions of SEPIC (Fig. 4) are mainly determined by inductors L_1 , L_2 and transformer TV . The dimensions of the transformer increase proportionally to the power, that is why the total dimensions of the cells' transformers may be considered as constant.

The dimensions of the inductor are proportional to the value of its inductance L and to the square of the bias current I_{02} .

The inductance of L_1 is:

$$L_1 = \frac{E_{peak}}{I_{peak(c)} f} \gamma, \quad (3)$$

where E_{peak} is peak voltage of electrical network, $I_{peak(c)}$ is peak value of the cell current.

It is necessary to provide the boundary current mode in the inductor L_1 , because it has the following advantages:

- the transistor opens at zero current through the inductor, that's why there are no switching losses or the losses associated with the diode recovery time,
- the total current through the inductor at some moments falls to zero, and the inductor is fully demagnetized,
- the inductor may be smaller comparing to the inductor used at continuous current mode.

The inductance L_2 is calculated from the condition of boundary current mode in inductors [11, 14]:

$$L_2 < \frac{L_1 \cdot U_{out}}{n \cdot U_{in}}, \quad (4)$$

where n is transformer ratio.

The capacitance C is calculated from the condition that the resonant frequency ω_r , defined by reactive elements C , L_1 , L_2 , should be significantly higher than the frequency of the network ω_g .

$$\omega_r = \frac{1}{\sqrt{C(L_1 + L_2)}} \gg \omega_g. \quad (5)$$

Other elements of the SEPIC are calculated by common formulas.

Based on the given relations, the parameters of two-phase transformerless charger designed on 300 W, 230 V, 50 Hz are calculated. The frequency of each converter cell $f = 100$ KHz, the duty cycle $\gamma = 0.5$ with phase shift 180° , $L_1 = 700$ mH, $L_2 = 3$ mH, $C_1 = 50$ nF.

The charger based on SEPIC topology with integrated PFC was investigated with different number of phases (cells) in MATLAB/Simulink. The main results are represented in the Table III.

The simulation models of two-phase charger and a charger cell, created in MATLAB Simulink, are shown in Fig. 6. The input current form and the current of the cells in large scale are shown in Fig. 7.

As shown in Fig. 7 a, the input current has some ripples, explained by nonlinearity of the real current form of a cell that shown in Fig. 7 b in a large scale.

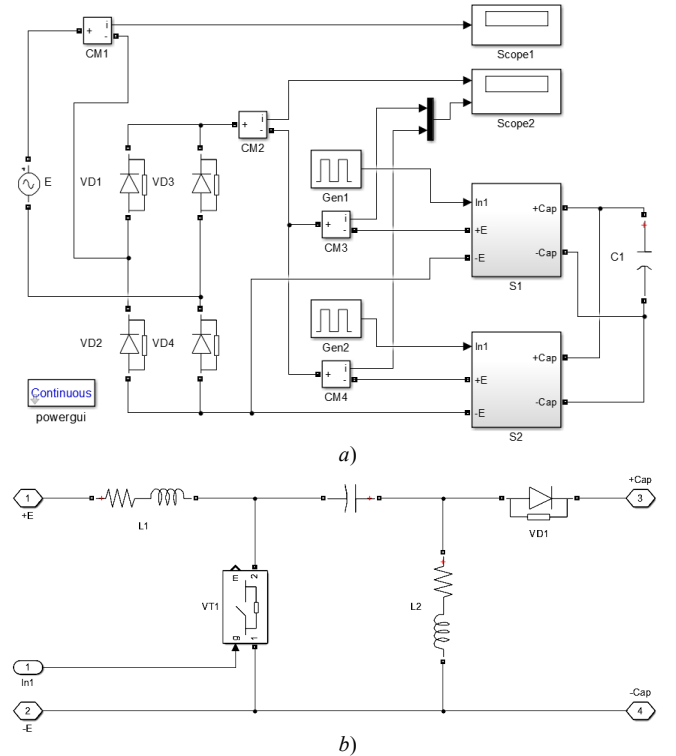

Fig. 6. The multiphase charger model (a) and one cell model (b).

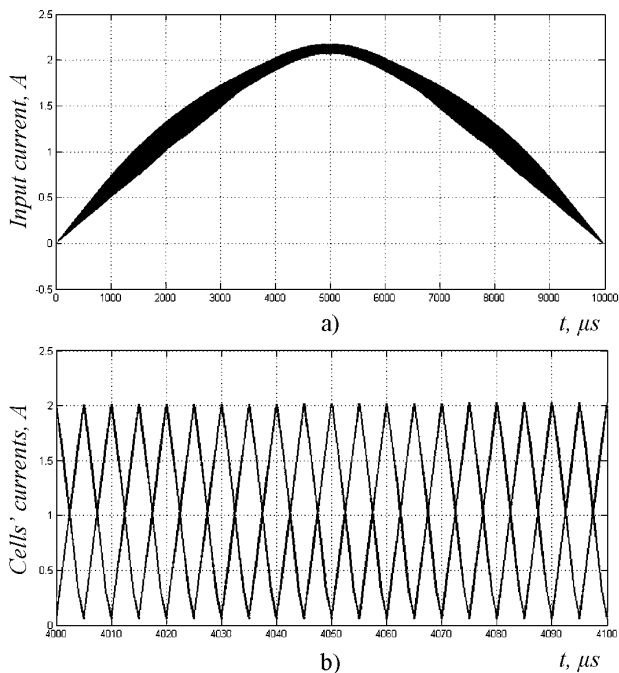

Fig. 7. The input current form (a) and the cells' currents in large scale (b).

TABLE III. THE RESULTS OF THE INVESTIGATING THE CHARGER BASED ON SEPIC TOPOLOGY WITH DIFFERENT NUMBER OF PHASES

Number of cells	THD, %	PF	d_c	d_{max}
1	55.86	0.8730	2.8	5
2	7.551	0.9972	2	2.9
3	6.736	0.9977	2	2.8
4	2.104	0.9998	1.2	2.4
5	2.520	0.9997	1.2	2.5

As we can see from the Table III, in case of using the two-phase structure of the charger, the value of *THD* of input current amounts to $\approx 7\%$, which provides the value of the power factor $> 99\%$. Therefore, even two-phase charger can provide excellent electromagnetic compatibility with the network in the above mode. The high-frequency ripples may be additionally decreased by installing the input small power *LC*-filter that improves the power factor.

VI. CONCLUSIONS

The study, which was carried out, confirmed the effectiveness of suggested circuit solutions for designing the input converter of the power supply for micro resistance welding. The multiphase principle of PFC construction based on SEPIC and use of Energy Storage topology of the input converter provide high quality of the input current form.

A two-phase structure of the input converter may be considered as optimal, because it provides high enough values of *THD* and *PF*, which meet the limits established in the current standards. Further increase of phase number improves the parameters of energy efficiency, but at the same time makes the circuit topology much more complicated.

REFERENCES

- [1] Y. E. Paerand, I. V. Bondarenko, O. F. Bondarenko, "Generators of current pulses for resistance welding", *Tekhnologiya i konstruirovaniye v elektronnoy apparature*, no. 3, 2008, pp. 25-30. URL: www.tkea.com.ua/tkea/2008/3_2008/st_06.htm.
- [2] M. Salem, "Control and Power Supply for Resistance Spot Welding (RSW)," 2011. URL: ir.lib.uwo.ca/etd/130/.
- [3] O. F. Bondarenko, P. S. Safronov, I. V. Bondarenko, and V. M. Sydorets, "Direct energy and energy storage circuit topologies of DC power supplies for micro resistance welding," in 2014 IEEE 34th International Scientific Conference on Electronics and Nanotechnology (ELNANO), 2014, pp. 468-471. DOI: 10.1109/ELNANO.2014.6873431.
- [4] C. A. Gallo, F. L. Tofoli, and J. A. Correa Pinto, "Two-Stage Isolated Switch-Mode Power Supply with High Efficiency and High Input Power Factor," *IEEE Transactions on Industrial Electronics*, vol. 57, no. 11, pp. 3754-3766, Nov. 2010. DOI: 10.1109/TIE.2010.2041735.
- [5] H. Wang, S. Dusmez, and A. Khaligh, "Design considerations for a level-2 on-board PEV charger based on interleaved boost PFC and LLC resonant converters," in 2013 IEEE Transportation Electrification Conference and Expo (ITEC), 2013, pp. 1-8. DOI: 10.1109/ITEC.2013.6574508.
- [6] O. F. Bondarenko, I. V. Bondarenko, P. S. Safronov, and V. M. Sydorets, "Effective circuit topology of DC power supply for micro resistance welding," in *Intelligent Energy and Power Systems (IEPS)*, 2014 IEEE International Conference on, 2014, pp. 68-70. DOI: 10.1109/IEPS.2014.6874204.
- [7] D. Kuzin, T. Khyzhniak, and O. Bondarenko, "Power quality improvement in single-phase power supplies for resistance welding," in *Electronics and Information Technology (EIT)*, 2016 International Conference on, 2016, pp. 30-34. DOI: 10.1109/ICEAIT.2016.7500985.
- [8] O. F. Bondarenko, V. M. Sydorets, and I. V. Bondarenko, "Development of Power Supplies for Micro Resistance Welding," *Scientific Herald of the DSEA*, no. № 3 (28), pp. 60-63, 2012. (rus).
- [9] B. Singh, B. N. Singh, A. Chandra, K. Al-Haddad, A. Pandey, and D. P. Kothari, "A review of single-phase improved power quality AC-DC converters," *IEEE Transactions on Industrial Electronics*, vol. 50, no. 5, pp. 962-981, Oct. 2003. DOI: 10.1109/TIE.2003.817609.
- [10] Product Comparison Matrix - Doc. 3000489.2, Maxwell Technologies Inc. http://www.maxwell.com/images/documents/Product_Comparison_Matrix_3000489_2.pdf
- [11] D. S. L. Simonetti, J. Sebastian, F. S. dos Reis, and J. Uceda, "Design criteria for SEPIC and Cuk converters as power factor preregulators in discontinuous conduction mode," in *Proceedings of the 1992 International Conference on Industrial Electronics, Control, Instrumentation, and Automation*, pp. 283-288. DOI: 10.1109/IECON.1992.254619.
- [12] IEC 61000-3-3:2013 Electromagnetic compatibility (EMC) Part 3-3: Limits - Limitation of voltage changes, voltage fluctuations and flicker in public low-voltage supply systems, for equipment with rated current ≤ 16 A per phase and not subject to conditional connection.
- [13] IEC 62135-2:2015 Resistance welding equipment Part 2: Electromagnetic compatibility (EMC) requirements.
- [14] C. H. Chan and M. H. Pong, "Input current analysis of interleaved boost converters operating in discontinuous-inductor-current mode," in *PESC97. Record 28th Annual IEEE Power Electronics Specialists Conference. Formerly Power Conditioning Specialists Conference 1970-71. Power Processing and Electronic Specialists Conference 1972*, vol. 1, pp. 392-398. DOI: 10.1109/PESC.1997.616754.
- [15] *Power Electronics Specialists Conference. Formerly Power Conditioning Specialists Conference 1970-71. Power Processing and Electronic Specialists Conference 1972*, vol. 1, pp. 392-398. DOI: 10.1109/PESC.1997.616754.



Denis Spitsyn received B.Sc. degree in electrical engineering from National Technical University of Ukraine "Igor Sikorsky Kyiv Polytechnic Institute", Department of Industrial Electronics in 2016. Presently he continues his study as a MSc student in the same department in Kyiv. His research interests include electrical and electronic engineering, control and systems engineering, power supplies and electrotechnology.



Oleksandr Bondarenko received B.Sc. and Dipl.-Ing. in electrical engineering with honours from Donbas Mining-Metallurgical Institute, Alchevsk, Ukraine, in 2002 and 2003, respectively. He received PhD degree in semiconductor converters of electricity from National Technical University of Ukraine "Kyiv Polytechnic Institute", Kyiv, Ukraine, in 2008. He is presently a postdoctoral student and an associate professor in Department of Industrial Electronics, National Technical University of Ukraine "Igor Sikorsky Kyiv Polytechnic Institute". He has over 50 publications including 5 patents for inventions. His research interests include electrical and electronic engineering, control and systems engineering, power supplies, resistance welding, electrotechnology. He is an IEEE member from 2011.